



PRESS RELEASE

Why name a slurry tanker MODULO?

As the name suggests, the JOSKIN MODULO2 slurry tanker is extremely modular! In addition, its capacities range from 2,500 to 20,000 litres. Finally, this fully galvanised model (tank and drawbar) is interesting for all sizes of farms, agricultural cooperatives and even contractors.

It is in fact a real Swiss Army knife as you can choose the options according to your needs, such as wheels with a diameter of 1,850 mm or of 875 mm wide on the single-axle model, and even 850/50R30.5 wheels (Ø 1,625 x 875 mm) on the double-axle version! At a time when there is increasing talk of soil compaction, this option is important for wet and/or soft ground.



Wheel recesses on single and double-axle machines with several options possible

The sprung drawbar not only offers you great comfort, but you can also change the position of the leaves in order to change the inclination of the tank. The same V-shaped drawbar fully protects the vacuum pump and offers the possibility of adjusting it to a flat position to ensure a perfect lubrication of the vanes from the front to the back of the compressor, thus increasing its service life. Do you prefer a spiral pump or the garda/vacuum combination? No problem. Everything is possible! Once again, we understand the reason for the name of this model, which offers so much modularity, and therefore so many solutions to users. The size of the pump will also depend on the volume of the tank or the user's choice.

The parking stand is located centrally under the drawbar, which allows a loaded vehicle to be unhitched and has the advantage of preventing the vehicle from twisting when parked.



To keep talking about comfort, the double-axle tankers are all equipped with the famous “Roll-Over” bogie. Its design with the position of the leaves under the axle squares not only lowers the centre of gravity, but also, and more importantly, improves the traction in difficult conditions, as the 1st axle is pulled up instead of being pushed into the ground.

This bogie is bolted to the galvanised chassis, which, just like with the single axle, will allow you to move the running gear back if you want to add an injector or a spreading boom at the back of the tank, as the Modulo2 is designed to be fitted with such implements. Important: adding weight to the rear of the tanker will change the balance of your machine and changing the position of the axles will allow you to distribute the weight more evenly or give more weight on the tractor for use in more difficult conditions.

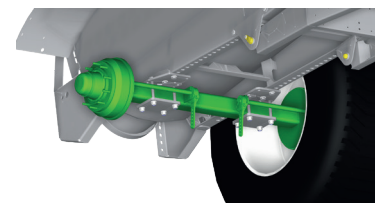
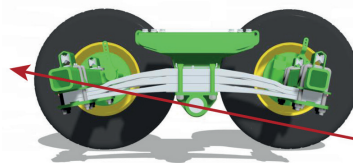
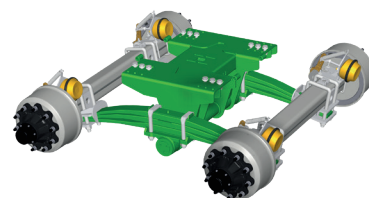

As for the pumping systems available, there is something for everyone, as there are at least five choices: the traditional side valve, the hydraulic and hermetic upper door, the sequential arm going down on the left or right and requiring only one hydraulic function, the side articulated arm or the dorsal boom. A turbo-filler with a hydraulically driven motor, can be added to all these tools.



The JOSKIN tanker is a short, sturdy machine with a very limited overhang when a spreading equipment is added. This philosophy makes it easy to manoeuvre in areas with difficult access.



It is impossible to list all of the 750 options available, but the most common and useful ones are the bolted eyelets instead of the welded ones for ease and speed of change in case of wear or if the user wants to change it.

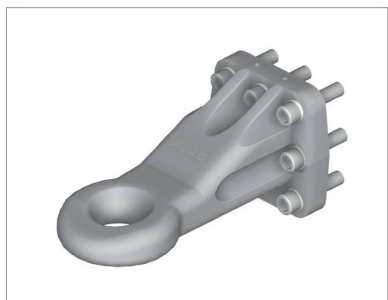

JOSKIN flat eyelet

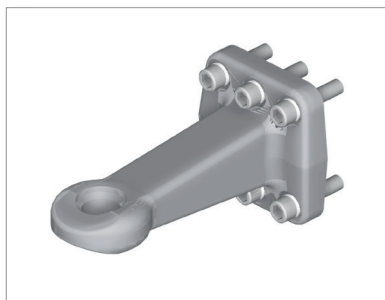

Rockinger flat eyelet

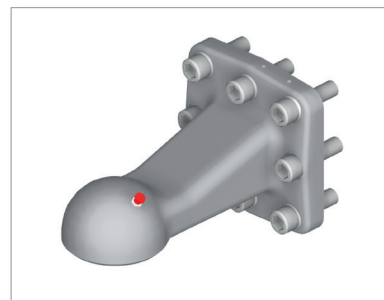

Knee-joint eyelet (Biba)

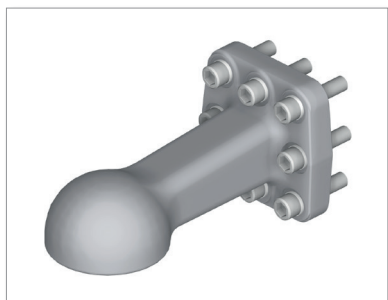

Scharmuller eyelet

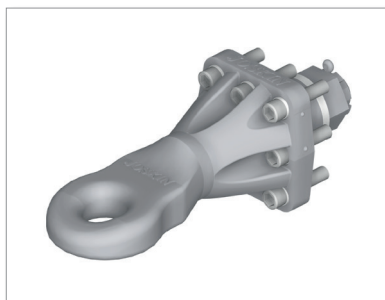

Flat swivel eyelet

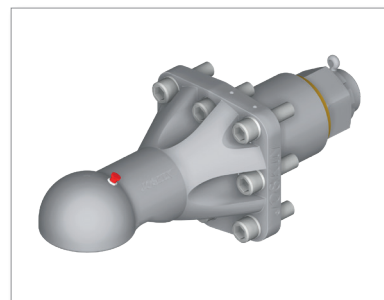

Swivel knee-joint eyelet

It should also be noted that the various indicators are mainly an aid when spreading, because when working with an injector, it is not easy to know when the tank is empty. To avoid this problem, there are various ways to see the level inside the tank: the large Ø 150 mm sight glass (see photo), the float gauge or the oblong sight glasses that you can place wherever you want.

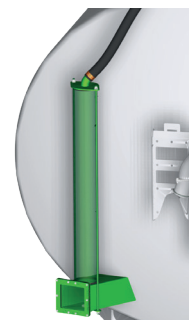

Do you have slurry to spread and want to make the most of it? Whether you are working on grassland, cereals or stubbles, you will find a wide choice of more than 60 spreading booms or injectors available from this supplier.

