

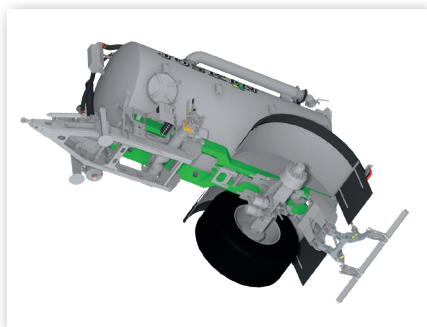

PRESS RELEASE

Cobra2, the new ultra-compact tanker from JOSKIN

JOSKIN has recently updated one of the big names in its range: the Cobra slurry tanker. While the second version of this model retains an extremely narrow chassis (600 mm) that allows the use of very wide wheels without exceeding 3 m in width, it also incorporates many new features. This is particularly true of its chassis. This is no longer independent, but is now an integrated chassis, allowing a lower vehicle with a lower centre of gravity. Inspired by the Volumetra model, awarded machine of the year 2017, the front part of the Cobra2 has also been redesigned. It now features a short, compact drawbar, effective suspension and a slurry feeding system below the tank. The rest of the Cobra2 has been enhanced with a few influences from the X-Trem2 (Machine of the Year 2020). The Cobra2 benefits from a compact design, a movable running gear, a robust 3-point rear linkage from Sauter and a rear hydraulic case integrated into the linkage, to name but a few. More information? Click [here](#).



Narrow Heavy Duty Chassis

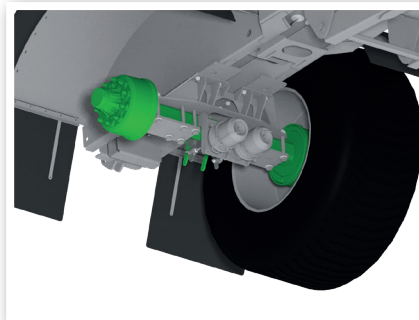

Movable Running Gear



Pre-Equipment for Compact Linkage

